

9. Representing constraint

Mechanics of Manipulation

Matt Mason

`matt.mason@cs.cmu.edu`

`http://www.cs.cmu.edu/~mason`

Carnegie Mellon

Chapter 1 Manipulation 1

- 1.1 Case 1: Manipulation by a human 1
- 1.2 Case 2: An automated assembly system 3
- 1.3 Issues in manipulation 5
- 1.4 A taxonomy of manipulation techniques 7
- 1.5 Bibliographic notes 8
- Exercises 8

Chapter 2 Kinematics 11

- 2.1 Preliminaries 11
- 2.2 Planar kinematics 15
- 2.3 Spherical kinematics 20
- 2.4 Spatial kinematics 22
- 2.5 Kinematic constraint 25
- 2.6 Kinematic mechanisms 34
- 2.7 Bibliographic notes 36
- Exercises 37

Chapter 3 Kinematic Representation 41

- 3.1 Representation of spatial rotations 41
- 3.2 Representation of spatial displacements 58
- 3.3 Kinematic constraints 68
- 3.4 Bibliographic notes 72
- Exercises 72

Chapter 4 Kinematic Manipulation 77

- 4.1 Path planning 77
- 4.2 Path planning for nonholonomic systems 84
- 4.3 Kinematic models of contact 86
- 4.4 Bibliographic notes 88
- Exercises 88

Chapter 5 Rigid Body Statics 93

- 5.1 Forces acting on rigid bodies 93
- 5.2 Polyhedral convex cones 99
- 5.3 Contact wrenches and wrench cones 102
- 5.4 Cones in velocity twist space 104
- 5.5 The oriented plane 105
- 5.6 Instantaneous centers and Reuleaux's method 109
- 5.7 Line of force; moment labeling 110
- 5.8 Force dual 112
- 5.9 Summary 117
- 5.10 Bibliographic notes 117
- Exercises 118

Chapter 6 Friction 121

- 6.1 Coulomb's Law 121
- 6.2 Single degree-of-freedom problems 123
- 6.3 Planar single contact problems 126
- 6.4 Graphical representation of friction cones 127
- 6.5 Static equilibrium problems 128
- 6.6 Planar sliding 130
- 6.7 Bibliographic notes 139
- Exercises 139

Chapter 7 Quasistatic Manipulation 143

- 7.1 Grasping and fixturing 143
- 7.2 Pushing 147
- 7.3 Stable pushing 153
- 7.4 Parts orienting 162
- 7.5 Assembly 168
- 7.6 Bibliographic notes 173
- Exercises 175

Chapter 8 Dynamics 181

- 8.1 Newton's laws 181
- 8.2 A particle in three dimensions 181
- 8.3 Moment of force; moment of momentum 183
- 8.4 Dynamics of a system of particles 184
- 8.5 Rigid body dynamics 186
- 8.6 The angular inertia matrix 189
- 8.7 Motion of a freely rotating body 195
- 8.8 Planar single contact problems 197
- 8.9 Graphical methods for the plane 203
- 8.10 Planar multiple-contact problems 205
- 8.11 Bibliographic notes 207
- Exercises 208

Chapter 9 Impact 211

- 9.1 A particle 211
- 9.2 Rigid body impact 217
- 9.3 Bibliographic notes 223
- Exercises 223

Chapter 10 Dynamic Manipulation 225

- 10.1 Quasidynamic manipulation 225
- 10.2 Brie y dynamic manipulation 229
- 10.3 Continuously dynamic manipulation 230
- 10.4 Bibliographic notes 232
- Exercises 235

Appendix A Infinity 237

Outline.

Constraint using contact screw and reciprocal product.

Repelling, reciprocal, contrary.

Relation to Reuleaux.

Examples.

Remember Reuleaux's method?

Perpendicular to constraint divides plane into positive IC's, negative IC's, and IC's of either sign.

Doesn't extend to three dimensions.

Great for humans, bad for computers.

Sometimes equations are better than pictures.

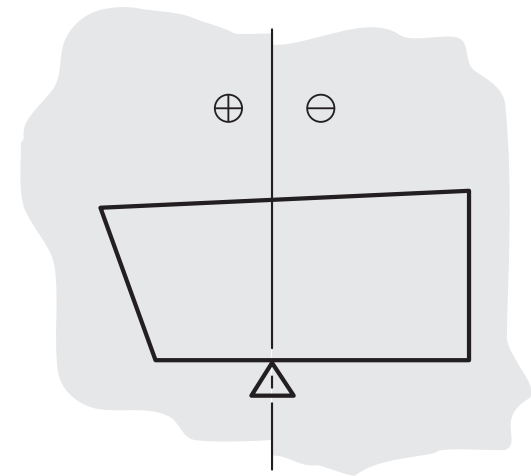

First order model of constraint

Let $\hat{\mathbf{u}}$ be contact normal, inward pointing

Let p be contact point in the constrained body

Let \mathbf{v}_p be the velocity of the point p .

Then we write the bilateral velocity constraint as

$$\hat{\mathbf{u}} \cdot \mathbf{v}_p = 0$$

and unilateral velocity constraint as

$$\hat{\mathbf{u}} \cdot \mathbf{v}_p \geq 0$$

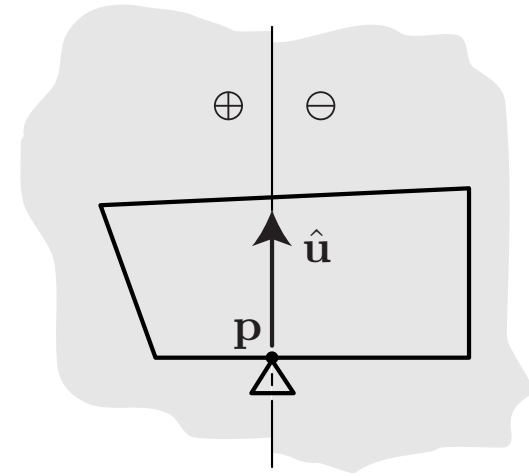

Constraint using screw coordinates

Let (ω, \mathbf{v}_0) be screw coordinates of body velocity

Then velocity of \mathbf{p} is

$$\mathbf{v}_p = \mathbf{v}_0 + \omega \times \mathbf{p}$$

We write the kinematic constraint

$$\hat{\mathbf{u}} \cdot (\mathbf{v}_0 + \omega \times \mathbf{p}) \geq 0$$

Distribute dot product, play with triple product ...

$$\hat{\mathbf{u}} \cdot \mathbf{v}_0 + (\mathbf{p} \times \hat{\mathbf{u}}) \cdot \omega \geq 0$$

Reciprocal product!

Contact screw

Define **contact screw** to be Plücker coordinates of the contact normal

$$(\mathbf{c}, \mathbf{c}_0) = (\mathbf{u}, \mathbf{p} \times \hat{\mathbf{u}})$$

Write the kinematic constraint as

$$(\mathbf{c}, \mathbf{c}_0) * (\boldsymbol{\omega}, \mathbf{v}_0) \geq 0$$

Reciprocal, contrary, repelling

Definition 3.3: A pair of screws is **reciprocal**, **contrary**, or **repelling**, if their reciprocal product is zero, negative, or positive, respectively.

Bilateral constraint: velocity screw (ω, \mathbf{v}_0) and contact screw $(\mathbf{c}, \mathbf{c}_0)$ must be *reciprocal*:

$$(\mathbf{c}, \mathbf{c}_0) * (\omega, \mathbf{v}_0) = 0$$

Unilateral constraint: velocity screw (ω, \mathbf{v}_0) and contact screw $(\mathbf{c}, \mathbf{c}_0)$ must be *reciprocal or repelling*:

$$(\mathbf{c}, \mathbf{c}_0) * (\omega, \mathbf{v}_0) \geq 0$$

Connection to Reuleaux's method

The contact screw $(\mathbf{c}, \mathbf{c}_0)$ is a zero-pitch screw—the Plücker coordinates of the contact normal.

For a planar motion of the $\hat{\mathbf{x}}\text{-}\hat{\mathbf{y}}$ plane, the body velocity twist (ω, \mathbf{v}_0) is also a zero-pitch screw—a pure rotation.

(ω, \mathbf{v}_0) is the Plücker coordinates of the rotation axis perpendicular to the $\hat{\mathbf{x}}\text{-}\hat{\mathbf{y}}$ plane.

Contact normal and directed rotation axis must be reciprocal or repelling. Directed rotation axis must point down (−) if it's to the right of the contact normal, and up (+) if it's to the left of the contact normal.

Copy the figure from the board

Ex 1: Screw coordinates of planar motions.

Choose three bilateral constraints aligned with the \hat{z} axis.

The screw coordinates for the constraints are:

$$(\mathbf{s}_1, \mathbf{s}_{01}) =$$

$$(\mathbf{s}_2, \mathbf{s}_{02}) =$$

$$(\mathbf{s}_3, \mathbf{s}_{03}) =$$

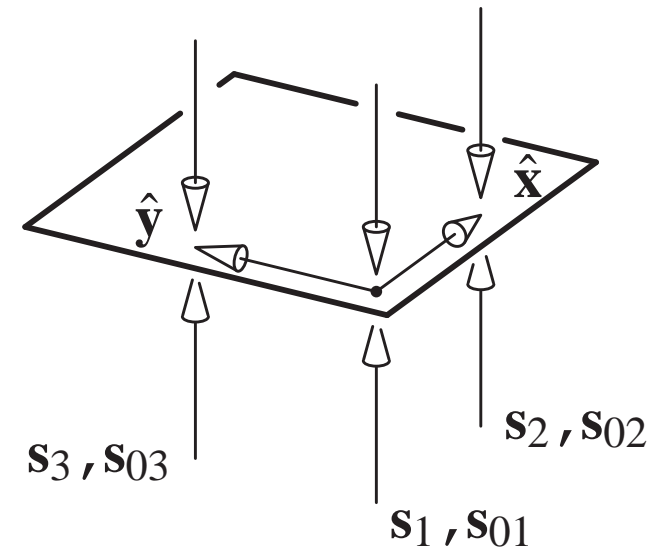

Ex 1: Screw coordinates of planar motions.

Choose three bilateral constraints aligned with the \hat{z} axis.

The screw coordinates for the constraints are:

$$(\mathbf{s}_1, \mathbf{s}_{01}) = (0, 0, 1, 0, 0, 0)$$

$$(\mathbf{s}_2, \mathbf{s}_{02}) =$$

$$(\mathbf{s}_3, \mathbf{s}_{03}) =$$

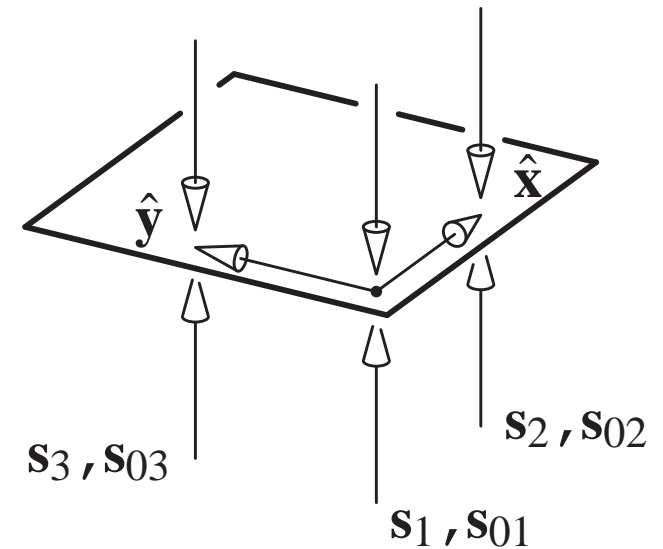

Ex 1: Screw coordinates of planar motions.

Choose three bilateral constraints aligned with the \hat{z} axis.

The screw coordinates for the constraints are:

$$(\mathbf{s}_1, \mathbf{s}_{01}) = (0, 0, 1, 0, 0, 0)$$

$$(\mathbf{s}_2, \mathbf{s}_{02}) = (0, 0, 1, 0, -1, 0)$$

$$(\mathbf{s}_3, \mathbf{s}_{03}) =$$

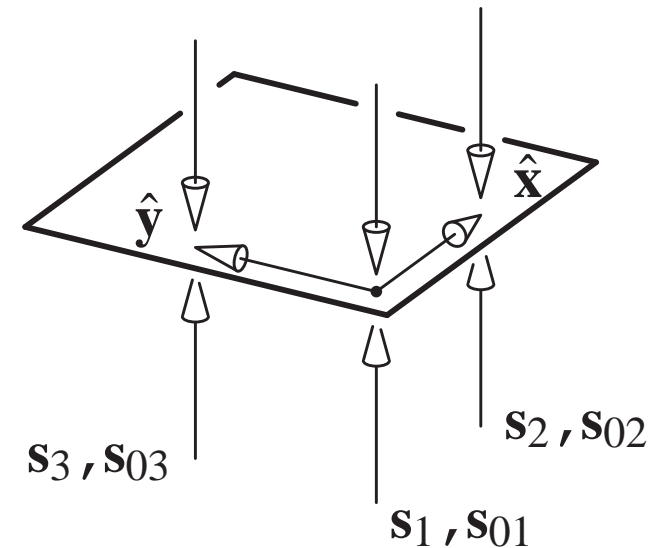

Ex 1: Screw coordinates of planar motions.

Choose three bilateral constraints aligned with the \hat{z} axis.

The screw coordinates for the constraints are:

$$(\mathbf{s}_1, \mathbf{s}_{01}) = (0, 0, 1, 0, 0, 0)$$

$$(\mathbf{s}_2, \mathbf{s}_{02}) = (0, 0, 1, 0, -1, 0)$$

$$(\mathbf{s}_3, \mathbf{s}_{03}) = (0, 0, 1, 1, 0, 0)$$

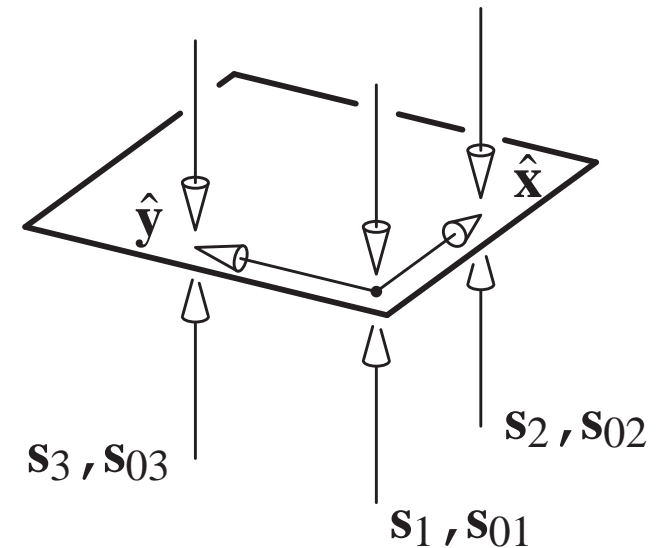

Ex 1: Screw coordinates of planar motions.

Choose three bilateral constraints aligned with the \hat{z} axis.

The screw coordinates for the constraints are:

$$(\mathbf{s}_1, \mathbf{s}_{01}) = (0, 0, 1, 0, 0, 0)$$

$$(\mathbf{s}_2, \mathbf{s}_{02}) = (0, 0, 1, 0, -1, 0)$$

$$(\mathbf{s}_3, \mathbf{s}_{03}) = (0, 0, 1, 1, 0, 0)$$

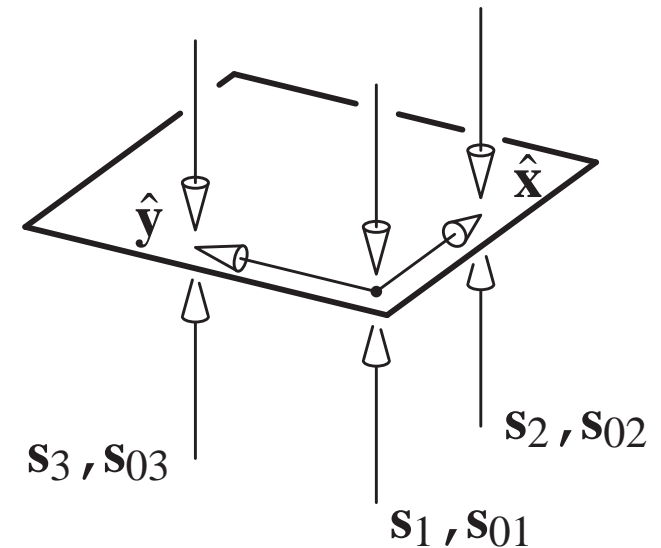

Let the twist be given by

$$(\mathbf{t}, \mathbf{t}_0) = (t_1, t_2, t_3, t_4, t_5, t_6)$$

Ex 1: Form reciprocal products.

The twist must be reciprocal to $(\mathbf{s}_1, \mathbf{s}_{01})$:

$$t_6 = 0$$

... to $(\mathbf{s}_2, \mathbf{s}_{02})$:

$$t_6 - t_2 = 0$$

... and to $(\mathbf{s}_3, \mathbf{s}_{03})$:

$$t_6 + t_1 = 0$$

Thus the twist must be of the form

$$(\mathbf{t}, \mathbf{t}_0) = (0, 0, t_3, t_4, t_5, 0)$$

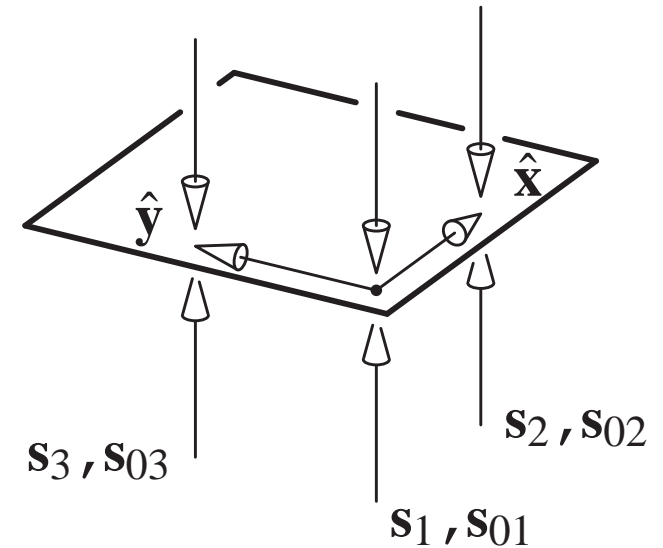

Ex 1: Interpreting the answer

The twist must be of the form

$$(\mathbf{t}, \mathbf{t}_0) = (0, 0, t_3, t_4, t_5, 0)$$

To get the pitch:

$$p = \frac{\mathbf{t} \cdot \mathbf{t}_0}{\mathbf{t} \cdot \mathbf{t}} = 0$$

The direction vector $(0, 0, t_3)$ is parallel to $\hat{\mathbf{z}}$

The point closest to the origin is

$$\begin{aligned} \frac{\mathbf{t} \times \mathbf{t}_0}{\mathbf{t} \cdot \mathbf{t}} &= (-t_5 t_3, t_4 t_3, 0) / t_3^2 \\ &= (-t_5 / t_3, t_4 / t_3) \end{aligned}$$

So the twist represents the rotation center using homogeneous coordinates. As a special case, when $t_3 = 0$, we obtain a pure translational velocity $(t_4, t_5, 0)$.

Ex 2: Squeezing the corners of a cube

We will consider the simpler bilateral problem

$$(\mathbf{s}_1, \mathbf{s}_{01}) =$$

$$(\mathbf{s}_2, \mathbf{s}_{02}) =$$

$$(\mathbf{s}_3, \mathbf{s}_{03}) =$$

$$(\mathbf{s}_4, \mathbf{s}_{04}) =$$

$$(\mathbf{s}_5, \mathbf{s}_{05}) =$$

$$(\mathbf{s}_6, \mathbf{s}_{06}) =$$

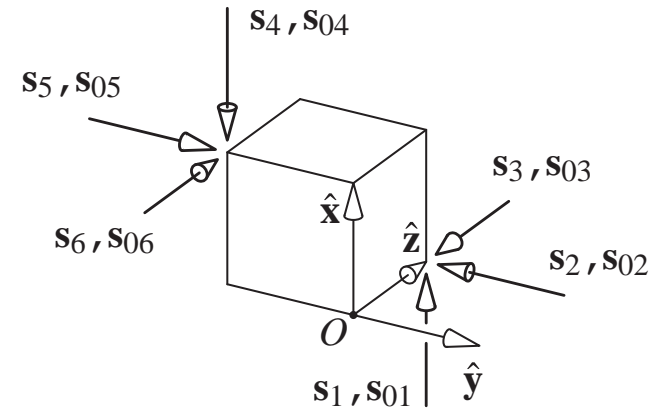

Ex 2: Squeezing the corners of a cube

We will consider the simpler bilateral problem

$$(\mathbf{s}_1, \mathbf{s}_{01}) = (1, 0, 0, 0, 1, 0)$$

$$(\mathbf{s}_2, \mathbf{s}_{02}) = (0, -1, 0, 1, 0, 0)$$

$$(\mathbf{s}_3, \mathbf{s}_{03}) = (0, 0, -1, 0, 0, 0)$$

$$(\mathbf{s}_4, \mathbf{s}_{04}) = (-1, 0, 0, 0, 0, -1)$$

$$(\mathbf{s}_5, \mathbf{s}_{05}) = (0, 1, 0, 0, 0, 1)$$

$$(\mathbf{s}_6, \mathbf{s}_{06}) = (0, 0, 1, -1, -1, 0)$$

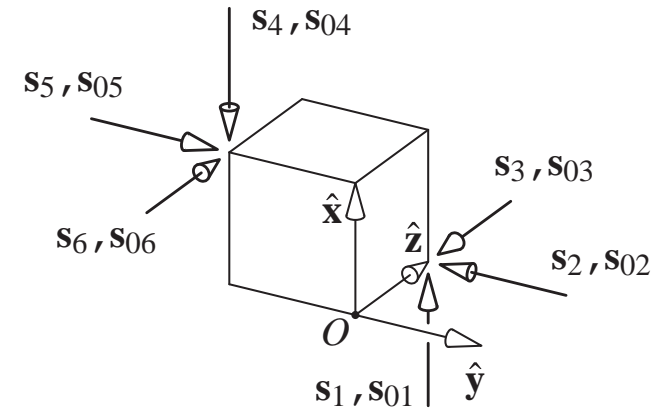

Let $(\mathbf{t}, \mathbf{t}_0)$ be a differential twist. Reciprocal with respect to $(\mathbf{s}_1, \mathbf{s}_{01})$

$$t_4 + t_2 = 0$$

Ex 2: Solving the constraint equations

Reciprocal to all 6 contact screws:

$$\begin{array}{ccccccc}
 t_4 & & & & +t_2 & & = 0 \\
 & -t_5 & & & +t_1 & & = 0 \\
 & & -t_6 & & & & = 0 \\
 -t_4 & & & & & -t_3 & = 0 \\
 & t_5 & & & & +t_3 & = 0 \\
 & & t_6 & -t_1 & -t_2 & & = 0
 \end{array}$$

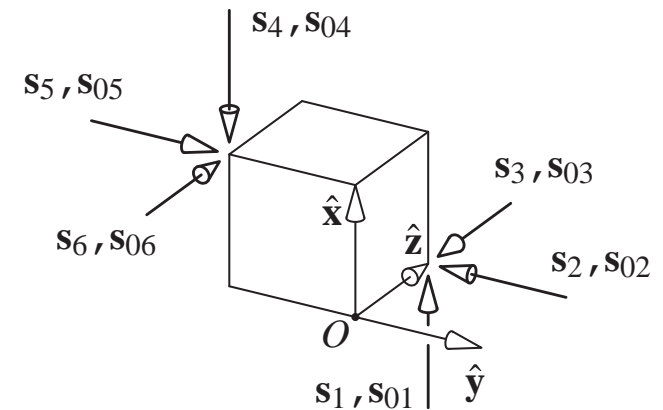

The solutions are of the form

$$(\mathbf{t}, \mathbf{t}_0) = k(1, -1, -1, 1, 1, 0)$$

Ex 2: Interpreting the solution

The solutions are of the form

$$(\mathbf{t}, \mathbf{t}_0) = k(1, -1, -1, 1, 1, 0)$$

Pitch: $\mathbf{t} \cdot \mathbf{t}_0 / \mathbf{t} \cdot \mathbf{t} = 0$.

Point on line closest to origin: $\mathbf{t} \times \mathbf{t}_0 / \mathbf{t} \cdot \mathbf{t}$
 $\mathbf{t} =$

Direction vector: $\mathbf{t} = (1, -1, -1)$.

I.e., as expected, the diagonal of the cube.

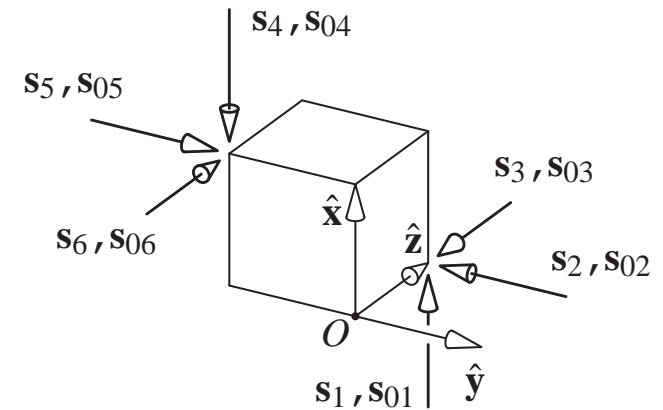

Next: Cspace transform and motion planning.

Chapter 1 Manipulation 1

- 1.1 Case 1: Manipulation by a human 1
- 1.2 Case 2: An automated assembly system 3
- 1.3 Issues in manipulation 5
- 1.4 A taxonomy of manipulation techniques 7
- 1.5 Bibliographic notes 8
- Exercises 8

Chapter 2 Kinematics 11

- 2.1 Preliminaries 11
- 2.2 Planar kinematics 15
- 2.3 Spherical kinematics 20
- 2.4 Spatial kinematics 22
- 2.5 Kinematic constraint 25
- 2.6 Kinematic mechanisms 34
- 2.7 Bibliographic notes 36
- Exercises 37

Chapter 3 Kinematic Representation 41

- 3.1 Representation of spatial rotations 41
- 3.2 Representation of spatial displacements 58
- 3.3 Kinematic constraints 68
- 3.4 Bibliographic notes 72
- Exercises 72

Chapter 4 Kinematic Manipulation 77

- 4.1 Path planning 77
- 4.2 Path planning for nonholonomic systems 84
- 4.3 Kinematic models of contact 86
- 4.4 Bibliographic notes 88
- Exercises 88

Chapter 5 Rigid Body Statics 93

- 5.1 Forces acting on rigid bodies 93
- 5.2 Polyhedral convex cones 99
- 5.3 Contact wrenches and wrench cones 102
- 5.4 Cones in velocity twist space 104
- 5.5 The oriented plane 105
- 5.6 Instantaneous centers and Reuleaux's method 109
- 5.7 Line of force; moment labeling 110
- 5.8 Force dual 112
- 5.9 Summary 117
- 5.10 Bibliographic notes 117
- Exercises 118

Chapter 6 Friction 121

- 6.1 Coulomb's Law 121
- 6.2 Single degree-of-freedom problems 123
- 6.3 Planar single contact problems 126
- 6.4 Graphical representation of friction cones 127
- 6.5 Static equilibrium problems 128
- 6.6 Planar sliding 130
- 6.7 Bibliographic notes 139
- Exercises 139

Chapter 7 Quasistatic Manipulation 143

- 7.1 Grasping and fixturing 143
- 7.2 Pushing 147
- 7.3 Stable pushing 153
- 7.4 Parts orienting 162
- 7.5 Assembly 168
- 7.6 Bibliographic notes 173
- Exercises 175

Chapter 8 Dynamics 181

- 8.1 Newton's laws 181
- 8.2 A particle in three dimensions 181
- 8.3 Moment of force; moment of momentum 183
- 8.4 Dynamics of a system of particles 184
- 8.5 Rigid body dynamics 186
- 8.6 The angular inertia matrix 189
- 8.7 Motion of a freely rotating body 195
- 8.8 Planar single contact problems 197
- 8.9 Graphical methods for the plane 203
- 8.10 Planar multiple-contact problems 205
- 8.11 Bibliographic notes 207
- Exercises 208

Chapter 9 Impact 211

- 9.1 A particle 211
- 9.2 Rigid body impact 217
- 9.3 Bibliographic notes 223
- Exercises 223

Chapter 10 Dynamic Manipulation 225

- 10.1 Quasidynamic manipulation 225
- 10.2 Brie y dynamic manipulation 229
- 10.3 Continuously dynamic manipulation 230
- 10.4 Bibliographic notes 232
- Exercises 235

Appendix A Infinity 237