

CGI and Forms

A detailed look at HTML forms

HTML Forms

- CGI programs often deal with user input.
- The only way to get user input from a browser is to use a form.
 - We already saw how to use an `ISINDEX` tag - this also allows user input but is limited to a single item.

Form Elements

- Each HTML form contains the following:
 - `<FORM>`, `</FORM>` tags
 - The `<FORM>` tag has two required attributes:
 - `METHOD` specifies the HTTP method used to send the request to the server (when the user submits the form).
 - `ACTION` specifies the URL the request is sent to.

FORM Method

- We have seen the two common methods used:
 - **GET**: any user input is submitted as part of the URI following a "?".
`GET foo?name=joe&cookie=oreo HTTP/1.0`
 - **POST**: any user input is submitted as the content of the request (after the HTTP headers).

Netprog 2001 - CGI and Forms

4

Sample POST Request

```
POST /dir/foo HTTP/1.0
User-Agent: Netscape 4.5
Content-Length: 20
Cookie: favorite=chocolatechip
ECACChamps: RPI

name=joe&cookie=oreo
```

Netprog 2001 - CGI and Forms

5

Form ACTION attribute

- The ACTION attribute specifies the URL to which the request is sent. Some examples:

```
ACTION="http://www.cs.rpi.edu/CGI_BIN/foo"
```

```
ACTION="myprog"
```

```
ACTION="mailto:hollingd@cs.rpi.edu"
```

Netprog 2001 - CGI and Forms

6

<FORM> Tag Examples

```
<FORM METHOD="POST"  
ACTION="http://www.foo.com/cgi-bin/myprog">  
  
<FORM METHOD="GET" ACTION="/cgi-bin/myprog">  
  
<FORM METHOD="POST"  
ACTION="mailto:shirley@pres.rpi.edu">
```

Netprog 2001 - CGI and Forms

7

Inside a form

- Between the <FORM> and </FORM> tags you define the text and *fields* that make up the form.
- You can use normal HTML tags to format the text however you want.
- The *fields* are defined using tags as well.

Netprog 2001 - CGI and Forms

8

Form Fields

- There are a variety of types of form fields:
 - text fields: text, password, textarea
 - radio buttons
 - checkboxes
 - buttons: user defined, submit, reset (clear)
 - hidden fields

Netprog 2001 - CGI and Forms

9

Input Fields

- There are a number of field types that allow the user to type in a string value as input.
- Each field is created using an `<INPUT>` tag with the attribute `TYPE`.

Netprog 2001 - CGI and Forms

10

Input Attributes

- The `TYPE` attribute is used to specify what kind of input is allowed: `TEXT`, `PASSWORD`, `FILE`, . . .
- Every `INPUT` tag must have a `NAME` attribute.

Netprog 2001 - CGI and Forms

11

TEXT Fields

- `TEXT` is the most common type of input:
 - user can enter a single line of text.
 - Additional attributes can specify:
 - the maximum string length - `MAXLENGTH`
 - the size of the input box drawn by the browser - `SIZE`
 - a default value - `VALUE`

Netprog 2001 - CGI and Forms

12

TEXT INPUT Examples

```
<INPUT TYPE=TEXT NAME=FOO>  
  
<INPUT TYPE="TEXT"  
      NAME="PIZZA"  
      SIZE=10  
      MAXLENGTH=20  
      VALUE="Pepperoni">
```

[textexample.html](#) Netprog 2001 - CGI and Forms

13

An example form

```
<FORM METHOD=POST ACTION=cgi-bin/foo>  
Your Name:  
<INPUT TYPE=TEXT NAME="Name"><BR>  
  
Your Age:  
<INPUT TYPE=TEXT NAME="Age"><BR>  
  
</FORM>
```

[form1.html](#)

Netprog 2001 - CGI and Forms

14

Submission Buttons

- Another type of INPUT field is the submission button.
- When a user clicks on a submit button the browser submits the contents of all other fields to a web server using the METHOD and ACTION attributes.

```
<INPUT TYPE=SUBMIT VALUE="press me">
```

Netprog 2001 - CGI and Forms

15

Reset Buttons

- An INPUT of type RESET tells the browser to display a button that will clear all the fields in the form.

```
<INPUT TYPE=RESET  
  VALUE="press me to clear form">
```

A Complete Form Example

```
<FORM METHOD=POST ACTION=cgi-bin/foo>  
Your Name:  
<INPUT TYPE=TEXT NAME="Name"><BR>  
  
Your Age: <INPUT TYPE=TEXT NAME="Age"><BR>  
  
<INPUT TYPE=SUBMIT VALUE="Submit">  
<INPUT TYPE=RESET>  
</FORM>
```

Tables and Forms

Tables are often used to make forms look pretty - remember that you can use any HTML tags to control formatting of a form.

Table/Form example

```
<FORM METHOD=POST ACTION=cgi-bin/foo>
<TABLE><TR>
  <TD>Your Name: </TD>
  <TD><INPUT TYPE=TEXT NAME="Name"></TD>
</TR><TR>
  <TD>Your Age:</TD>
  <TD> <INPUT TYPE=TEXT NAME="Age"></TD>
</TR><TR>
  <TD><INPUT TYPE=SUBMIT VALUE="Submit"></TD>
  <TD><INPUT TYPE=RESET></TD>
</TR></TABLE>
</FORM>
```

[form3.html](#)

Netprog 2001 - CGI and Forms

19

Other Inputs

- Checkboxes

- present user with items that can be selected or deselected. Each checkbox has a name and a value and can be initially selected/deselected

- Example checkbox definitions:

```
<INPUT TYPE=checkbox name=chocchip value=1>
<INPUT TYPE=checkbox name=oreo value=1>
```

Netprog 2001 - CGI and Forms

20

Checkbox example

```
<FORM METHOD=POST ACTION=cgi-bin/foo>
Select all the cookies you want to order:<BR>

<INPUT TYPE=CHECKBOX NAME=Oreo Value=1>
  Oreo<BR>
<INPUT TYPE=CHECKBOX NAME=Oatmeal Value=1>
  Oatmeal<BR>
<INPUT TYPE=CHECKBOX CHECKED NAME=ChocChip
  Value=1>
  Chocolate Chip<BR>

<INPUT TYPE=SUBMIT VALUE=Submit>
</FORM>
```

[check1.html](#)

Netprog 2001 - CGI and Forms

21

Radio Buttons

- Radio Buttons are like checkbox except that the user can select only one item at a time.
- All radio buttons in a group have the same NAME.

```
<INPUT TYPE=radio name=cookie value=chocchip>  
<INPUT TYPE=radio name=cookie value=oreo>  
<INPUT TYPE=radio name=cookie value=oatmeal>
```

Netprog 2001 - CGI and Forms

22

Radio Button Example

```
<FORM METHOD=POST ACTION=cgi-bin/foo>  
Select all the cookies you want to order:<BR>  
  
<INPUT TYPE=RADIO NAME=Cookie Value=Oreo> Oreo <BR>  
<INPUT TYPE=RADIO NAME=Cookie Value=Oatmeal> Oatmeal  
<BR>  
<INPUT TYPE=RADIO CHECKED NAME=Cookie Value=ChocChip>  
ChocolateChip<BR>  
  
<INPUT TYPE=SUBMIT VALUE=Submit>  
</FORM>
```

[radio1.html](#) Netprog 2001 - CGI and Forms

23

Multiline Text

- The TEXTAREA tag creates an area where the user can submit multiple lines of text.
- This is not another type of <INPUT> tag!

Netprog 2001 - CGI and Forms

24

TEXTAREA Attributes

- Each TEXTAREA tag has attributes NAME, COLS and ROWS.

```
<TEXTAREA name=address rows=5 cols=40>  
default text goes here (or can be empty)  
</TEXTAREA>
```

Netprog 2001 - CGI and Forms

25

TEXTAREA example

```
<FORM METHOD=POST ACTION=cgi-bin/foo>  
Please enter your address in the space  
provided:<BR>  
<TEXTAREA NAME=address COLS=40 ROWS=5>  
</TEXTAREA>  
<BR>  
<INPUT TYPE=SUBMIT VALUE=Submit>  
</FORM>
```

[textarea1.html](#)

Netprog 2001 - CGI and Forms

26

Form Submission

- When the user presses on a SUBMIT button the following happens:
 - browser uses the FORM method and action attributes to construct a request.
 - A query string is built using the (name,value) pairs from each form element.
 - Query string is URL-encoded.

Netprog 2001 - CGI and Forms

27

Input Submissions

- For each checkbox selected the name,value pair is sent.
- For all checkboxes that are not selected - nothing is sent.
- A single name,value pair is sent for each group of radio buttons.

Netprog 2001 - CGI and Forms

28

Other Form Field Types

- There are other form field types:
 - SELECT - pulldown menu or scrolled list of choices.
 - Image Buttons
 - Push Buttons (choice of submit buttons)

Netprog 2001 - CGI and Forms

29

Hidden Fields

- Nothing is displayed by the browser.
- The name,value are sent along with the submission request.

```
<INPUT TYPE=HIDDEN  
      NAME=SECRET  
      VALUE=AGENT>
```

Netprog 2001 - CGI and Forms

30

Hidden does not mean secure!

- Anyone can look at the source of an HTML document.
 - hidden fields are part of the document!
- If a form uses GET, all the name/value pairs are sent as part of the URI
 - URI shows up in the browser as the location of the current page

[hidden1.html](#)

Netprog 2001 - CGI and Forms

31

Typical FORM CGI setup

- User fills out a form and presses submit.
- CGI program gets a set of name,value pairs - one for each form field.
- CGI decides what to do based on the name,value pairs
 - sometimes creates a new form based on the submission.

Netprog 2001 - CGI and Forms

32

Exercise: Student Grade DB

- Come up with a description of CGI programs that do the following:
 - get a student name from a form.
 - If the student is found in a database, a form is now sent back to the browser with a list of grades that can be changed.
 - Once the grade change form is submitted the entries are used to update the database.

Netprog 2001 - CGI and Forms

33

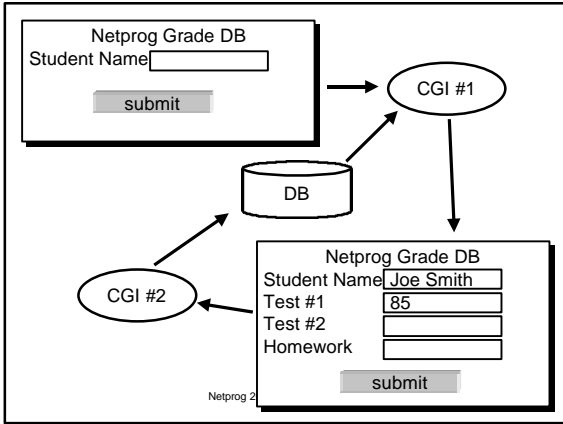

Student Grade DB

- Some Issues:
 - How is the initial form made available to a user?
 - How is the second form made available to a user?
 - What does a request look like that CGI #1 might get?
 - What does a request look like that CGI #2 might get?

Netprog 2001 - CGI and Forms 35

Hacking Exercise

I have a (phony) student grade system running at:
<http://cgi.cs.rpi.edu/~hollingd/netprog/StudentDB/>

The CGI programs are basically what we just described (cgi1 and cgi2).
 Can you find a way to change joe's grade without knowing the instructor password?

Netprog 2001 - CGI and Forms 36

Exercise (cont.)

HINTS:

- The field names in the login form are:
 - password, name
- The field names in the submission (grade change) form are:
 - email, name, test1, test2, homework.
- There is a record for the student "joe"

Netprog 2001 - CGI and Forms

37

Student Access

- Now consider allowing students to access the *system*.
 - We don't want students to be able to change grades.
 - We don't want students to be able to view other student's grades.
 - We want to provide access to the details of each individual grade (via a link).

Netprog 2001 - CGI and Forms

38

