

## Final CCNA Voice Lab

Description: Please write erase any existing configuration on your UC500 and start from scratch for this final lab. You will have two class weeks (4/27 and 5/3) to complete this lab.

Diagram:

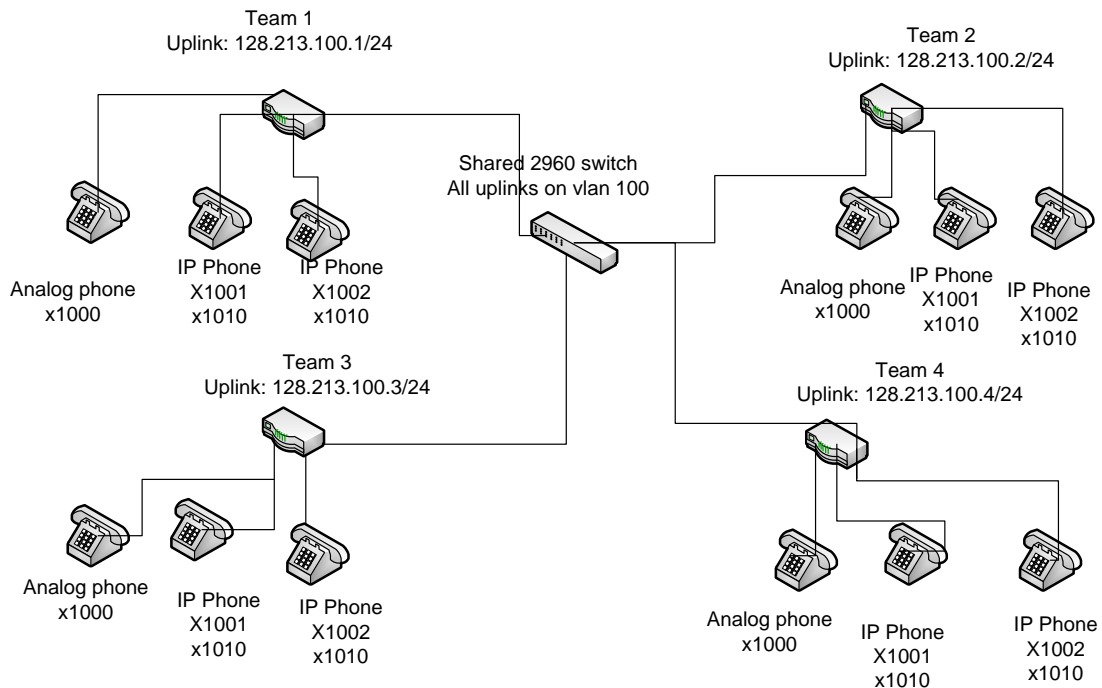

1. Basic Configuration
  - 1.1 Configure ssh access via vty ports. Username of ccie password ccie.
  - 1.2 Configure uplink port. Ensure you can ping every other teams uplink port.
  - 1.3 Configure voice vlan of 200. Your IP address is 128.213.20X.1/24 where X=team number.
  - 1.4 Configure DHCP pool of 128.213.20X.10-128.213.20X.50. Provide IP address of TFTP server needed for phones through DHCP option 150.
2. SCCP Configuration
  - 2.1 Setup your device as tftp server
  - 2.2 Enable telephony-service. Set max-ephones to 24 and max-dn to 50. Configure QoS (ip qos ?). Tell phones where to find configuration files (cnf-file location flash: ). Allow auto registration.
  - 2.3 Change interdigit timeout to 15 seconds (default is 10).
  - 2.4 Set timezone on phones to our timezone. Set phone to display 24 hour clock for time display.
3. Phone Registration.

- 3.1 Get your phones to register and be able to call each other. Not you are sharing a line between your two IP phones. Also note that every team using same extensions – this is not a mistake.
- 3.2 Configure your dial peer for your analog phone and make sure your IP phones can call it and vice versa.
4. Dial Plan configuration
  - 4.1 Each team assigned a prefix to identify calls. Team 1 = 111, Team 2 = 222, Team 3=333, Team 4=444. Configure your dial peers appropriately. For example for Team 1 to call team 2's ext 1001 team 1 phone must dial 2221001. Make sure all calling is working as expected amongst teams.
5. Voicemail – unity express configuration
  - 5.1 Get voicemail working. Ensure you can leave and retrieve messages for each of your phones and that voicemail working across dial peers. Get MWI working on your IP phones.
6. Phone Features
  - 6.1 Configure barge feature on your shared lines within your team and test. Barge allows a user on a shared line to 'barge' into an ongoing call on the shared line. This requires you to configure a new phone template (using softkeys for barge and join and use that template on both IP phones).
  - 6.2 Configure Do Not Disturb on phone with extension 1002. Test this feature. Let phone user control feature.
  - 6.3 On the phone with x1002 configure a third line of x1003. Next configure intercom feature between x1001 and x1003. This is done by creating speed dial on x1001 -> x1003 and on the phone housing line x1003 it should be set to auto-answer with speaker. Test this.
  - 6.4 Configure distinctive ring tones on phone with x1001. All internal calls (calls from within your UC500 ) should use chirp1, all external calls coming in from other team's should use chirp2.